

UL-1000-10A-11F

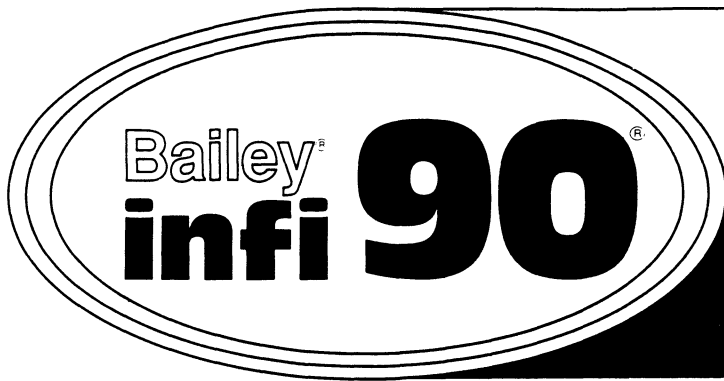

E97-370

Instruction

Communication Fiber Optic Termination Unit (NTCF01/02/03)

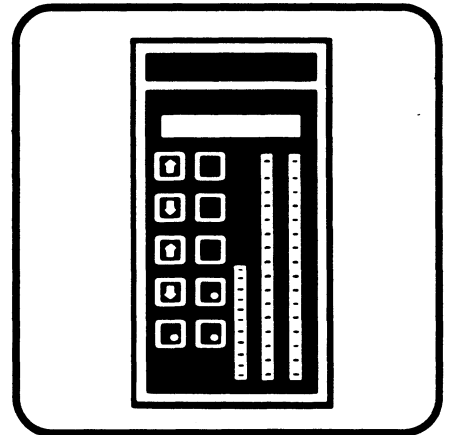
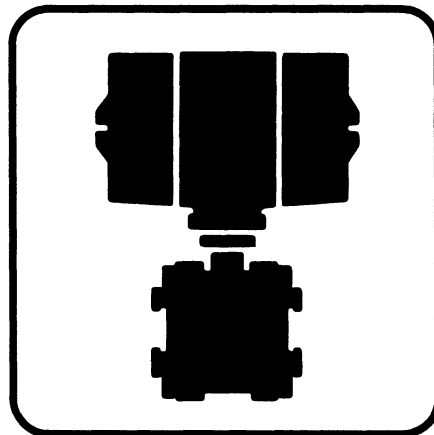
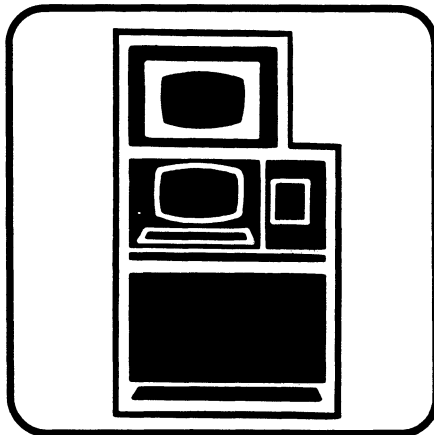
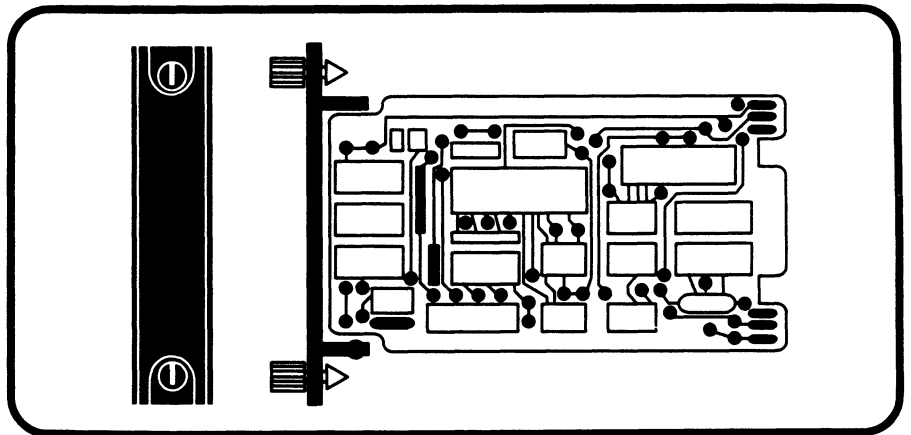
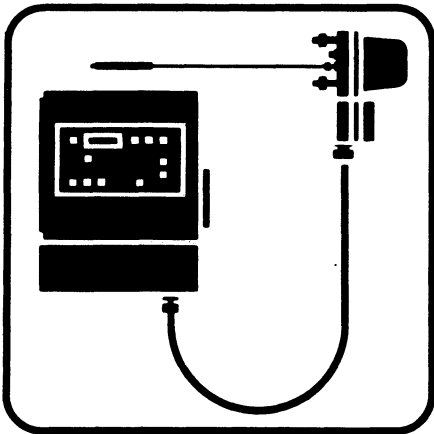

WARNING notices as used in this manual apply to hazards or unsafe practices which could result in personal injury or death.

CAUTION notices apply to hazards or unsafe practices which could result in property damage.

NOTES highlight procedures and contain information which assist the operator in understanding the information contained in this manual.

WARNING

INSTRUCTION MANUALS

DO NOT INSTALL, MAINTAIN OR OPERATE THIS EQUIPMENT WITHOUT READING, UNDERSTANDING AND FOLLOWING THE PROPER **Elsag Bailey** INSTRUCTIONS AND MANUALS, OTHERWISE INJURY OR DAMAGE MAY RESULT.

RADIO FREQUENCY INTERFERENCE

MOST ELECTRONIC EQUIPMENT IS INFLUENCED BY RADIO FREQUENCY INTERFERENCE (RFI). CAUTION SHOULD BE EXERCISED WITH REGARD TO THE USE OF PORTABLE COMMUNICATIONS EQUIPMENT IN THE AREA AROUND SUCH EQUIPMENT. PRUDENT PRACTICE DICTATES THAT SIGNS SHOULD BE POSTED IN THE VICINITY OF THE EQUIPMENT CAUTIONING AGAINST THE USE OF PORTABLE COMMUNICATIONS EQUIPMENT.

POSSIBLE PROCESS UPSETS

MAINTENANCE MUST BE PERFORMED ONLY BY QUALIFIED PERSONNEL AND ONLY AFTER SECURING EQUIPMENT CONTROLLED BY THIS PRODUCT. ADJUSTING OR REMOVING THIS PRODUCT WHILE IT IS IN THE SYSTEM MAY UPSET THE PROCESS BEING CONTROLLED. SOME PROCESS UPSETS MAY CAUSE INJURY OR DAMAGE.

AVERTISSEMENT

MANUELS D'OPERATION

NE PAS METTRE EN PLACE, REPARER OU FAIRE FONCTIONNER CE MATERIEL SANS AVIORS, COMPRIS ET SUIVI LES INSTRUCTIONS REGLIMENTAIRES DE **Elsag Bailey** TOUTE NEGLIGENCE A CET EGARD POURRAIT ETRE UNE CAUSE D'ACCIDENT OU DE DEFAILLANCE DU MATERIEL.

PERTURBATIONS DE LA FREQUENCE RADIOPHONIQUE

LA PLUPART DES EQUIPEMENTS ELECTRONIQUES SONT SENSIBLES AUX PERTURBATIONS DE LA FREQUENCE RADIO. DES PRECAUTIONS DEVRONT ETRE PRISES LORS DE L'UTILISATION DE MATERIEL DE COMMUNICATION PORTATIF. LA PRUDENCE EXIGE QUE LES PRECAUTIONS A PRENDRE DANS CE CAS SOIENT SIGNALEES AUX ENDROITS VOULUS DANS VOTRE USINE.

PERTES PROCEDE RENVERSEMENTS

L'ENTRETIEN DOIT ETRE ASSURE PAR UN PERSONNEL QUALIFIE ET EN CONSIDERATION DE L'ASPECT SECURITAIRE DES EQUIPEMENTS CONTROLES PAR CE PRODUIT. L'ADJUSTEMENT ET/OU L'EXTRACTION DE CE PRODUIT LORSQU'IL EST INSERE A UN SYSTEME ACTIF PEUT OCCASIONNER DES A-COUPS AU PROCEDE CONTROLE. SUR CERTAINS PROCEDES, CES A-COUPS PEUVENT EGALEMENT OCCASIONNER DES DOMMAGES OU BLESSURES.

NOTICE

The information contained in this document is subject to change without notice.

Elsag Bailey Company, its affiliates, employees, and agents, and the authors of and contributors to this publication specifically disclaim all liabilities and warranties, express and implied (including warranties of merchantability and fitness for a particular purpose), for the accuracy, currency, completeness, and/or reliability of the information contained herein and/or for the fitness for any particular use and/or for the performance of any material and/or equipment selected in whole or part with the user of or in reliance upon information contained herein. Selection of materials and/or equipment is at the sole risk of the user of this publication.

This document contains proprietary information which is protected by copyright. All rights are reserved. No part of this document may be photocopied or reproduced without the prior written consent of **Elsag Bailey Company**.



E97-370

Update

Communication Fiber Optic Termination Unit (NTCF01/02/03)

This instruction update adds informations regarding the COMMUNICATION FIBER OPTIC TERMINATION UNIT, NTCF01/02/03.

Integrate the attached pages into your COMMUNICATION FIBER OPTIC TERMINATION UNIT manual (E97-370), in accordance with the following instructions:

1. Replace page I-II, III-IV, 1-1/1-2, 2-3/2-4, 2-9/2-10.
2. Remove page 2-11.

After the update has been added, insert this page of update instructions into the front of the manual immediately behind the front cover.

Preface

The NTCFOX family of Termination Units interfaces PCU loop communication modules to Fiber-optic INFI 90 Plant Loop and INFINET systems.

The Loop Interface Module (INLIM03) is used with Plant Loop and Network Interface Slave (INNIS01) is for INFINET.

This product instruction explains the installation and various set-ups for configuring the NTCF01/02/03 to interface with Plant Loop of INFINET.

List of Effective Pages

Total number of pages in this manual is 32, consisting of the following:

Page No.	Change Date
Preface	Original
List of Effective Pages	Original
III through V	Original
1-1 through 1-7	Original
2-1 through 2-10	Original
3-1	Original
4-1 through 4-2	Original
5-1	Original

When an update is received, insert the latest changed pages and dispose of the superseded pages.

NOTE: On an updated page, the changed text or table is indicated by a vertical bar in the outer margin of the page adjacent to the changed area. A changed figure is indicated by a vertical bar in the outer margin next to the figure caption. The date the update was prepared will appear beside the page number.

Table of Contents

	Page
SECTION 1 - INTRODUCTION	1-1
GENERAL INFORMATION	1-1
INTENDED USER	1-1
SYSTEM DESCRIPTION	1-2
MODULE OPERATION	1-3
Transmission	1-4
Reception	1-4
Power supply	1-4
INSTRUCTION CONTENTS	1-5
HOW TO USE THIS MANUAL	1-5
REFERENCE DOCUMENTS	1-5
NOMENCLATURE	1-5
FAMILY MEMBER	1-5
SPECIFICATIONS	1-6
PIN ASSIGNMENT	1-7
<hr/>	
SECTION 2 - INSTALLATION	2-1
INTRODUCTION	2-1
SPECIAL HANDLING	2-1
UNPACKING AND INSPECTION	2-1
FIBER OPTIC BUDGET	2-2
JUMPER SETTING	2-3
Jumpers E1 and E2	2-3
Jumper E3	2-3
Jumper E4 to E6	2-3
LED	2-4
Mother board	2-4
LED's conditions	2-5
Daughter board	2-6
LED DS1	2-6
INSTALLING THE TERMINATION UNIT	2-7
CABLE INSTALLATION	2-8
POWER WIRING	2-9
BACK-UP BATTERY INSTALLATION	2-10
Auxiliary Back-up Battery Installation	2-10
<hr/>	
SECTION 3 - MAINTENANCE	3-1
INTRODUCTION	3-1
MAINTENANCE SCHEDULE	3-1
<hr/>	
SECTION 4 - REPAIR/REPLACEMENT PROCEDURES	4-1
INTRODUCTION	4-1
TERMINATION UNIT REPLACEMENT	4-1
ON-LINE REPLACEMENT	4-2
<hr/>	
SECTION 5 - SUPPORT SERVICES	5-1
INTRODUCTION	5-1
TECHNICAL DOCUMENTATION	5-1

List of Figures

No.	Title	Page
1-1.	NTCF Application example	1-1
1-2.	Mixed fiber-coaxial-twinaxial connection	1-2
1-3.	NTCF Block Diagram	1-3
2-1.	NTCF Jumpers location (daughter boards)	2-3
2-2.	Mother board LED's location	2-4
2-3.	Daughter Board LED location	2-6
2-4.	Mounting the NTCF on the Field Termination Panel	2-7
2-5.	Securing the NTCF with two screws	2-7
2-6.	Connectors Assignment	2-8
2-7.	Terminals Location	2-9

List of Tables

No.	Title	Page
3-1.	Maintenance Schedule	3-1

Safety Summary

GENERAL WARNINGS

Equipment Environment

All components, whether in transportation, operation or storage, must be in a non-corrosive environment.

Electrical Shock Hazard During Maintenance

Disconnect power or take precautions to ensure that contact with energized parts is avoided when servicing.

Special Handling

This unit uses Electrostatic Sensitive Devices (ESD).

SPECIFIC CAUTION

We strongly recommend that you turn off cabinet power before doing any termination module wiring. Failure to do so could result in equipment damage. Do not apply power until you verify all wire connections.

Sommaire de Sécurité

AVERTISSEMENT D'ORDRE GÉNÉRAL

Environnement de l'équipement

Ne pas soumettre les composants à une atmosphère corrosive lors du transport, de l'entreposage ou de l'utilisation.

Risques de chocs électriques lors de l'entretien.

S'assurer de débrancher l'alimentation ou de prendre les précautions nécessaires à éviter tout contact avec des composants sous tension lors de l'entretien.

Precautions de Manutention

Ce unit contient des composants sensibles aux décharges electro-statiques

ATTENTION D'ORDRE SPÉCIFIQUE

Il est fortement recommandé de débrancher l'alimentation électrique du cabinet avant d'effectuer tout connexion aux cartes de raccordement des modules. Des dommages aux équipements pourraient survenir dans le cas contraire. Ne pas rebrancher l'alimentation avant que toutes les connexions aient été vérifiées.

SECTION 1 - INTRODUCTION

GENERAL INFORMATION

The NTCT0x family of Fiber Optic Termination Units is designed to allow signals transmission on INFI 90 INFINET or Plant Loop by means of a fiber optic cable. Intermixing, on the same ring, of COAX, TWINAX and F.O. cables is also allowed.

The module is installed in each communication node of the system between the INNIS INLIM03 unit (see Figure 1-1.) and the optic transmission medium; it is also completely transparent to the protocols of the communication loop.

All of the baud rates of Plant Loop (500kbits per second) and INFINET (2 and 10Mbits per second) are allowed.

The different members of the family realize the electrical to optical, optical to optical and optical to electrical interface.

The maximum internode distance achieved can be, using a good quality fiber, 3 km. This value can be limited by configuration.

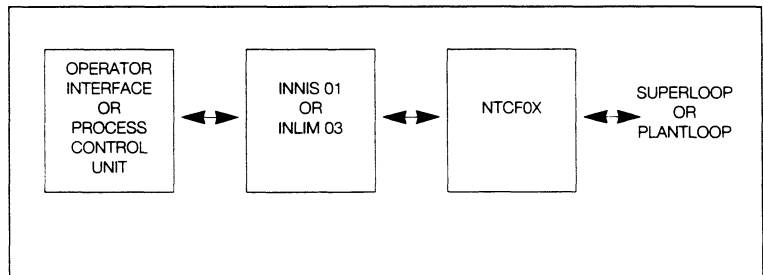

Figure 1-1. NTCF Application example.

Previous version of NTCF Family included also: NTCF11/12/13, capable of 11 km optical link. Starting from 4Q 94 NTCF11/12/13 will be no more produced.

INTENDED USER

Technicians should read this manual before installing and operating the NTCF. **DO NOT** put the NTCF into operation until you read and understand this instruction.

SYSTEM DESCRIPTION

The communication system of the "Optic" INFINET consists of a double fiber optic loop in the usual redundant ring configuration.

The connections between adjacent nodes of the loop are created by a monofiber cable.

The cables interface with the node through the electro-optic receiver-transmitter module, called NTCF0x, which is designed to convert the input-output electric signals of the slave interface (INNIS) unit of the node to/from optic signals conveyed on the network optic fiber between one node and another.

The NTCF0x module is physically connected to the F.O. cables by means of optic connectors.

- The ring continuity in case of node failure or power down is guaranteed by an active by-pass. The serial data of each communication loop will close through this path, thus assuring transmission continuity of the system.
- The power supply of each of the two channels of the NTCF0x module is maintained, in case of failure, by a local back-up battery.
- It will also be possible to interconnect adjacent nodes with a 50 ohm coaxial or 95 ohm twinaxial cable, maintaining the characteristics of the typical signals of the INFINET, using the appropriate member of the NTCF family.
- Therefore, it will be possible to create a mixed fiber-coaxial-twinaxial ring as shown in Figure 1-2.

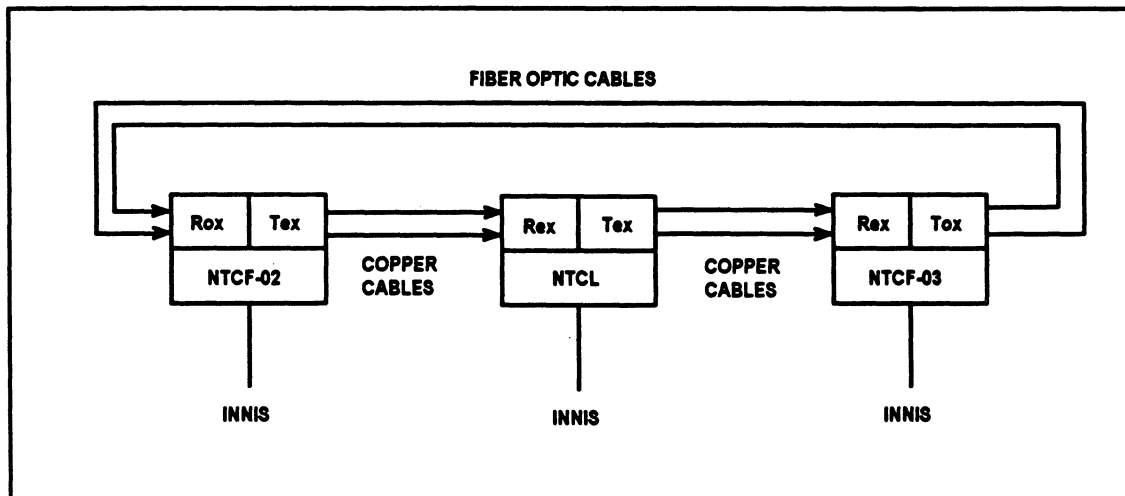

Figure 1-2. Mixed fiber-coaxial-twinaxial connection.

MODULE OPERATION

Refer to the block diagram illustrated in Figure 1-3.

Each channel of the NTCFxx module is subdivided into three main parts:

- Transmission
- Reception
- Power supply.

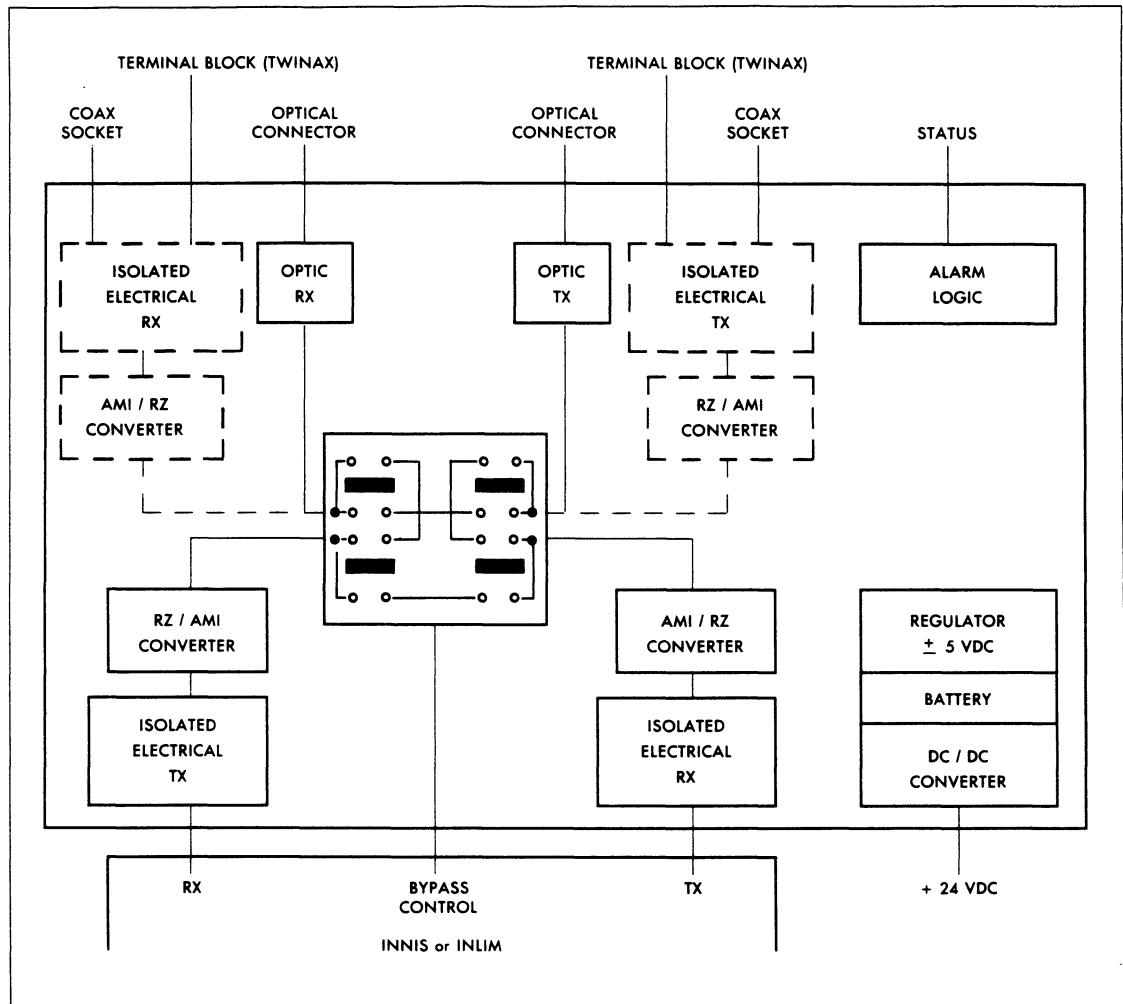

Figure 1-3. NTCF Block diagram.

Transmission

The AMI code signal leaving the INNIS unit of the node is sent, through a transformer, to a threshold circuit that converts the 3 levels of the code into a RZ-format binary signal, corresponding to the positive and negative pulses of the code, this signal is sent through a driver circuit to the F.O. transmitter.

The F.O. transmitter portion consists of an electro-optic conversion module that operates at 850 nm.

A relay-based switch is inserted between the threshold circuit and the electro-optic module to implement the by-pass. The by-pass command coming from the INNIS module is activated by a failure signal.

Reception

The optic signal received by the fiber is sent to an optic-electrical receiver that reconstructs the RZ signal.

A subsequent logic block converts the RZ code into the AMI format to be sent to the INNIS module.

Power supply

The power supply of the module is guaranteed through a +24 VDC source delivered by the Network 90/INFI 90 power supplies.

A DC/DC converter provides the stabilized power sources + 5 V; - 5 V and - 15 V which supply all module circuits.

A on board back-up battery allows loop integrity during node power down periods.

A charge-pump circuit provides the necessary charge current to the back-up battery.

A special circuit periodically checks the status of the battery, issuing a visual alarm signal; the battery status is also made available on a normally open fototransistor through a dedicated terminal block.

An external auxiliary back-up battery can be connected, but it will be neither charged nor checked by the NTCF0x circuitry.

INSTRUCTION CONTENTS

This manual has five sections.

Section 1, **Introduction**, provides an overview of the NTCF.
 Section 2, **Installation**, explains physical installation, wiring and cable requirements, jumper configurations, etc.
 Refer to section 3, **Maintenance**, for scheduled maintenance requirements.
 Refer to section 4, **Repair/Replacement Procedures**, for how to replace a module.
 Use section 5, **Support Service**, when ordering replacement parts.

HOW TO USE THIS MANUAL

Read this manual thoroughly before installing the NTCF.
 Read the **Installation** section thoroughly. Do the steps in order. Do not operate the NTCF until you complete all steps in this section. Refer to the appendices for specific module and cable questions.

REFERENCE DOCUMENTS

Document Number	Document
I-E96-601	Infinet Network Interface Slave (INNIS01)
I-E96-605	Loop Interface Module (INLIM03)
I-E96-909-3	I/O Power Panel
I-E96-506	Modular Power System (MPS)

NOMENCLATURE

Hardware	Nomenclature
Infinet Network Interface Slave	INNIS01
PLANT-LOOP Loop Interface Module	INLIM03
Field Termination Panel	NFTP01
Cables	
Termination Unit Cable (NTCF to NIS)	NKLS01
Termination Unit Cable (NTCF to LIM)	NKLS03

FAMILY MEMBER

Nomenclature	Rx	Tx
NTCF-01	3 km optical	3 km optical
NTCF-02	3 km optical	electrical
NTCF-03	electrical	3 km optical

SPECIFICATIONS

Optical Cable Type	
Core/cladding	62.5/125 micrometer
Attenuation at 850 nm	3 dB/km max
Mode	Multimode
Index	Graded
Bandwidth	≥ 100 MHz
Max difference in length between Loop 1 and Loop 2	800 m
Optical Connector Type	
Style	ST
Connector loss	1 dB max
Optical Power	
Budget	≥ 11 dB
Twinax Cable type	
Type	RG22B/U
Impedance	95 Ω
Capacitance	52.5 pF/m
Attenuation	6.9 dB/100 m at 50 MHz
Cable length	It depends on system configuration. Please contact Elsag Bailey
Coax Cable type	
Type	ETHERNET
Impedance	50 Ω
Capacitance	85 pF/m
Attenuation	1 dB/100 m at 50 MHz
Cable length	It depends on system configuration. Please contact Elsag Bailey
By-pass	
Maximum number of contiguous nodes in bypass simultaneously	It depends on system configuration. Please contact Elsag Bailey
Electric Interface to INNIS or INLIM	
Format	AMI
Rated level RX	2.8 Vpp ± 1 dB
Rated level TX	2.8 Vpp ± 1 dB
RX, TX impedance	95 ± 5 Ω
Bypass signal	Open-collector and local LED
Battery status	N.O. fototransistor and local LED
Power supply	
External Supply current at ± 24 VDC	+ 24 VDC ± 15% NTCF01 450 mA typical NTCF02 350 mA typical NTCF03 400 mA typical
Auxiliary battery (external, not included in NTCFox)	
Rated minimum capacity (Ah) for auxiliary battery	10 times supply current
Rated voltage for auxiliary battery	7.2 V
Back-up battery	
Rated voltage	7.2 V
Number of elements	6
Type	Ni-Cd
Capacity	1.2 Ah
Autonomy	≥ 4 h
Recovery time from complete discharge	≤ 16 h

SPECIFICATIONS

SPECIFICATIONS (continued)

Environmental conditions	
Operating temperature	0 to 50° C
Storage temperature	-10 to 50° C / -10 to 70° C without batteries
Mechanical dimensions	
Maximum length	181 mm
Maximum width	177 mm
Maximum depth	110 mm
Mounting	Screw mounts to the field termination panel
Cooling requirements	No cooling necessary when used in Bailey cabinets and operated within stated environmental limits.
Air quality	Bailey equipment should be operated and stored in a non-corrosive environment.

PIN ASSIGNMENT

Terminal Number	Assignment	Terminal Number	Assignment
TB1		TB3	
1	Loop 2 In, +	1	Loop 1 Out, +
2	Loop 2 In, -	2	Loop 1 Out, -
3	Loop 2 In, Shield	3	
TB2		TB4	
1	Loop 2 Out, +	1	Loop 1 In, +
2	Loop 2 Out, -	2	Loop 1 In, -
3		3	Loop 1 In, Shield
TB5	Common	TB6	+ 24 VDC
TB7		TB8	
1	Allarm 2, +	1	Allarm 1, +
2	Allarm 2, -	2	Allarm 1, -
3	Power Status 2	3	Power Status 1
TB10	Battery 1, +	TB9	Battery 2, +
TB12	Battery 1, -	TB11	Battery 2, -
TB14	Aux. Battery 1, +	TB13	Aux. Battery 2, +
TB16	Aux. Battery 1, -	TB15	Aux. Battery 2, -
BNC Number	Assignment	BNC Number	Assignment
J3	Loop 2 In	J5	Loop 1 Out
J4	Loop 2 Out	J6	Loop 1 In
Metalized hole placed between TB2 and TB3	Chassis GND		

NOTE: Twinax cables connected to the terminals. Coax cables connect to the BNC.

SECTION 2 - INSTALLATION

NOTE	In the following only the optical to optical family members and the case of an INFINET ring will be depicted, in order to avoid confusion and misunderstanding. The transposition in the case of electro-optic and opto-electric family members, or of a Plant Loop ring is a very simple task.
-------------	--

INTRODUCTION

The NTCF0x can mount on a Field Termination Panel within a Process Control Unit (PCU), remotely. The maximum distance between the NTCF0x and INLIM03/INNIS01 is 10 m.

This section explains the steps to install the NTCF0x.

The installation procedure covers handling, jumper configuration, cable connection and physical installation.

SPECIAL HANDLING

The NTCF0x T.U.'s use Electrostatic Sensitive (ESD) devices. Follow these handling procedure:

1. Keep the T.U. in the special anti-static bag until you are ready to install in the system. Save the bag for future use.
2. Ground the anti-static bag before opening.
3. Verify that all devices connected to the T.U. are properly grounded before using it.
4. Avoid touching the circuitry when handling the T.U.
5. Maintain the T.U.'s F.O. connectors protected with their plastic caps when the fiber is not connected.
6. Maintain the fiber connectors protected with their plastic caps when the fiber is not attached to the T.U.

NOTE: Grounding straps (field static kits) must be used when installing or removing the T.U. to configure or change jumper setting.

UNPACKING AND INSPECTION

1. Examine the T.U. immediately to verify that no damage has occurred in transit.
2. Notify the nearest Elsag Bailey Sales/Service Office of any damage.
3. File a claim for any damage with the transportation company that handled the shipment.

INTRODUCTION

4. Use the original packing material and/or container to store the T.U.
5. Store the T.U. in an environment of good air quality, and free temperature and moisture extremes.
6. NTCF0x T.U. are shipped with the wires of the two back-up batteries disconnected from the related terminals of the T.U., in order to avoid battery discharge. Connect the wires only when activating the T.U. Disconnect the wires when storing the T.U. or disactivating for more than 4 hours.

FIBER OPTIC BUDGET

The minimum Power Budget of NTCF0x is 11dB. The Power Budget determines the maximum distance over which the link can operate. The losses in a link, measured in decibels, are due to fiber losses specified in dB/km, and losses due to connectors or splices in the link. The 62.5/125 fiber is available in 2 km maximum length. Choose fibers with the maximum loss rate of 3 dB/km, at 850 nm.

Example:

If 3 km of cable is used, the insertion loss due to the fiber is:

$$3 \text{ dB/km} \times 3 \text{ km} = 9 \text{ dB at } 850 \text{ nm}$$

Connector losses, if installed properly, amount to an average of < 1 dB per connector. Splices, if properly executed, amount to an average of 0.15 dB per splice. If one connection is made along the cable, as in this example, the total loss due to connectors is 1 dB. This is due to the fact that the rated power budget takes in account the transmitter and receiver connector's loss. The total loss to the system is:

$$9 \text{ dB} + 1 \text{ dB} = 10 \text{ dB at } 850 \text{ nm}$$

Though the guaranteed power budget takes in account the active components aging, is a good policy to assure a safety margin of a minimum of 2 dB for component degrading.

JUMPER SETTING

See Figure 2-1 for jumper locations. These jumpers must be set to match the path communication with the NTCF0x.

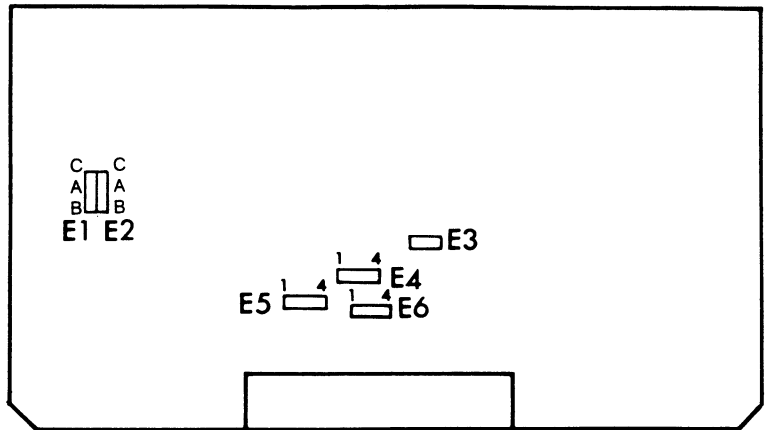

Figure 2-1. NTCF Jumpers location (daughter boards).

Jumpers E1 and E2

Jumpers E1 and E2 are factory set, depending on version. When the receiver section is electrical, E1 and E2 are jumpered on position AB. When the receiver section is optical, E1 and E2 are jumpered on position AC.

CAUTION **Never change E1 and E2 jumpers position.**

Jumper E3

Jumper E3 is used to adapt, in electrical receiver version, the receiver impedance to the ring. When a twinax cable is used, jumper E3 is not mounted. When a coax cable is used, jumper E3 is mounted.

Jumpers E4 to E6

Jumper E4 to E6 are used to set, on electrical receiver version, the data rate of the receiver. For communication rate of 500 Kbaud E4 to E6 are jumpered between pins 1 and 2. For communication rate of 2 Mbaud E4 to E6 are jumpered between pins 2 and 3. For communication rate of 10 Mbaud E4 to E6 are jumpered between pins 3 and 4.

LED

Mother board

The NTCF0x has, on the mother board, five LED lights to tell the condition of the hardware. See Figure 2-2. for LEDs locations on the mother board.

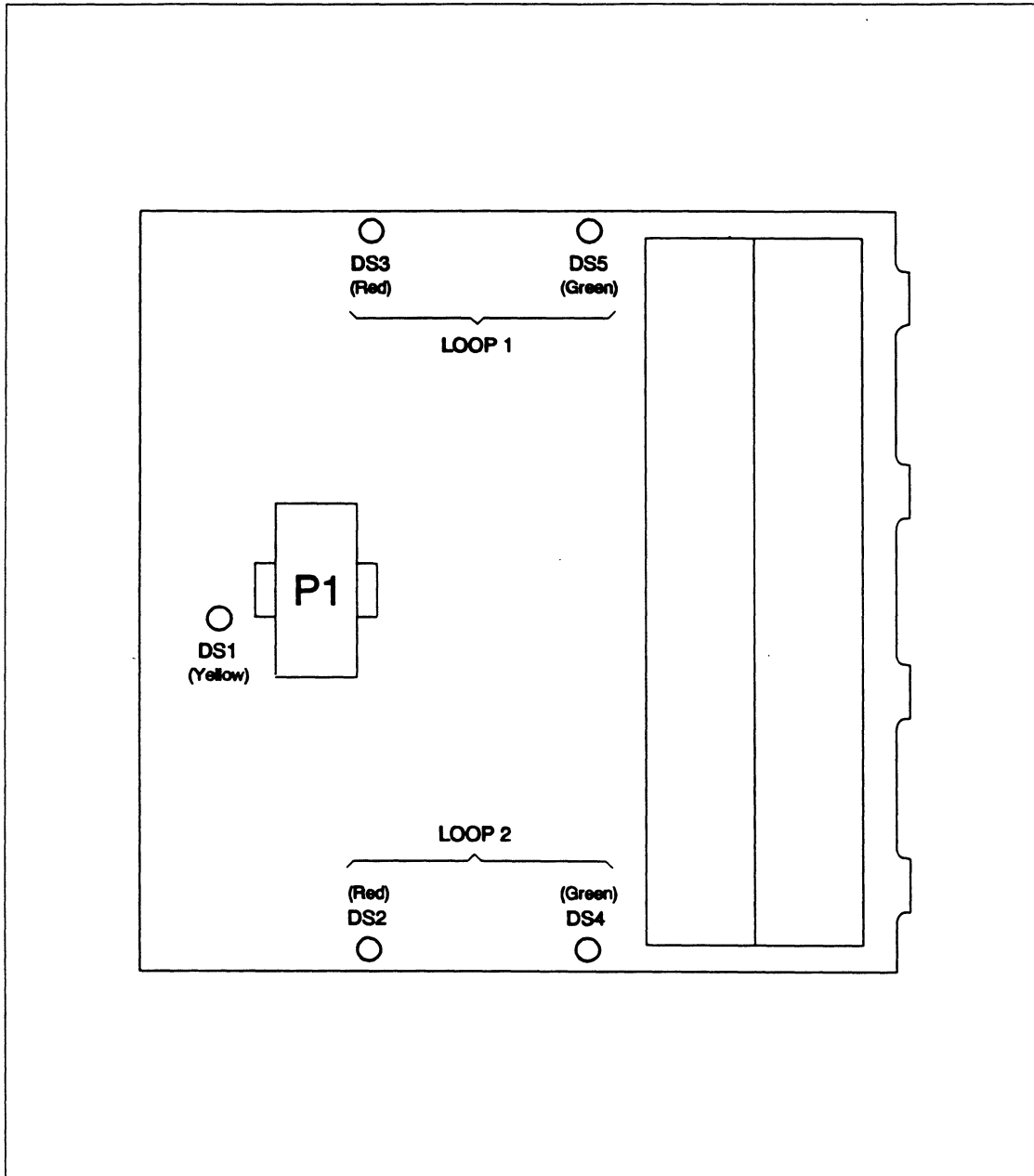

Figure 2-2. Mother board LEDs location

LED's conditions

DS1 (Yellow)	On-Line/By-pass	ON: On-Line OFF: by-pass
DS2 (red)	Loop 2 battery status	ON: Battery out of order if DS4 ON as well Battery under charge if DS4A OFF OFF: normal conditions
DS3 (red)	Loop 1 battery status	ON: Battery out of order if DS5 ON as well Battery under charge if DS5 OFF. OFF: normal conditions
DS4 (green)	Loop 2 battery charger	ON: charge is terminated OFF: charge is in progress
DS5 (green)	Loop 1 battery charger	ON: charge is terminated OFF: charge is in progress

Daughter Board

The NTCF01/02 have one LED on each daughter board to tell the link status. See Figure 2-3. for LED location on the daughter board.

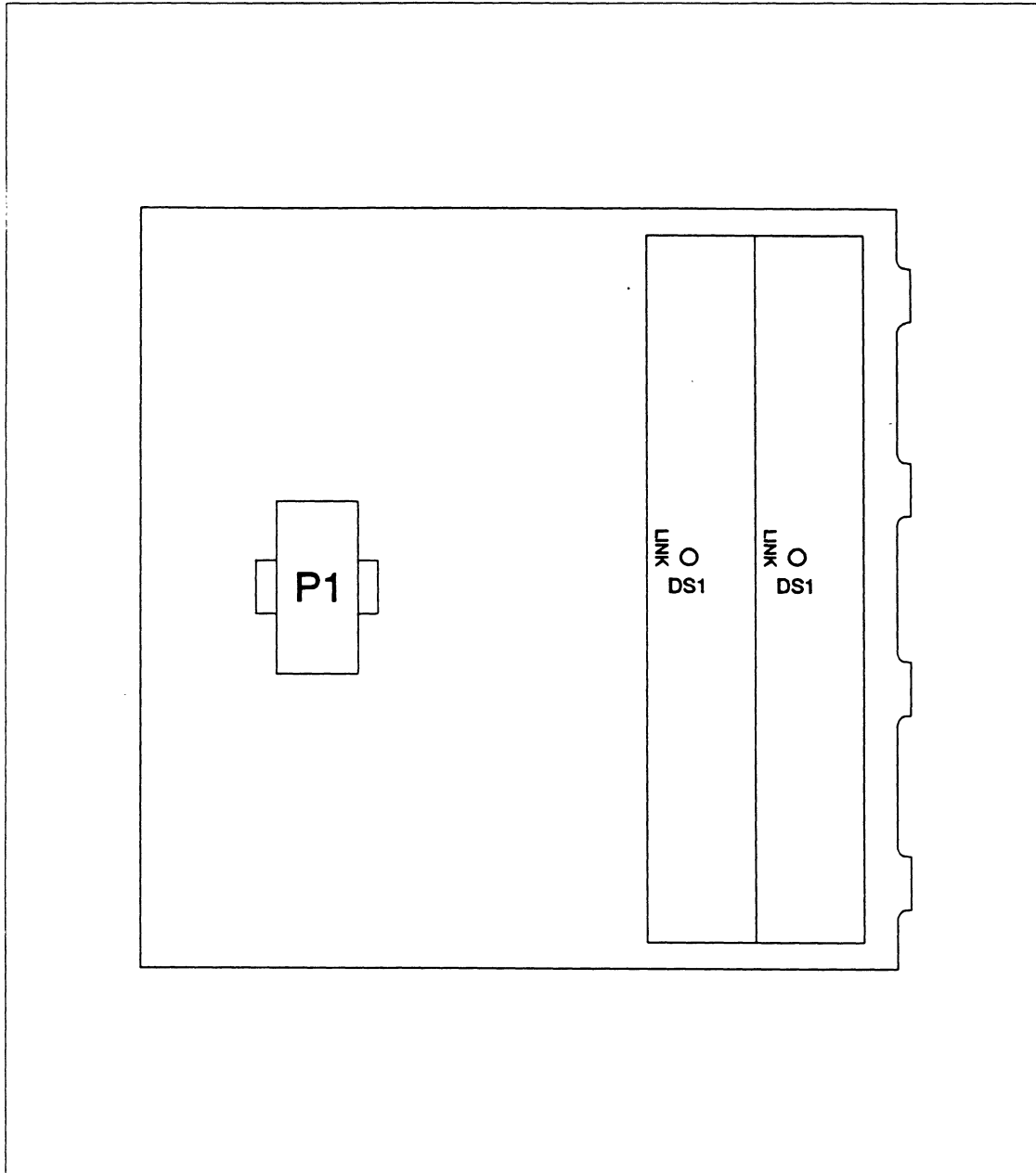

Figure 2-3. Daughter Board LED location

LED DS1

The DS1 is a red LED that monitors the link status of the optical receiver. When DS1 is off insufficient optical power is inputted on the optical receiver.

LED DS1

INSTALLING THE TERMINATION UNIT

1. Insert the tabs of the circuit board into the proper slots of the termination panel standoff as shown in Figure 2-4. and slide the circuit board into position.

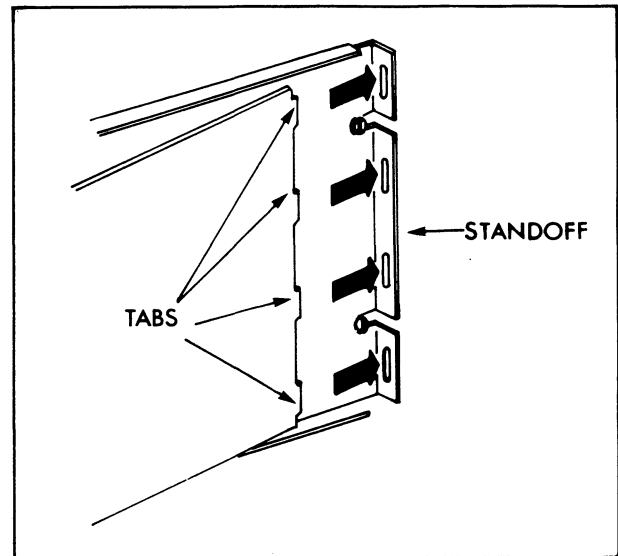

Figure 2-4. Mounting the NTCF on the Field Termination Panel

2. Secure the termination unit circuit board on the field termination panel with two screws as shown in Figure 2-5.

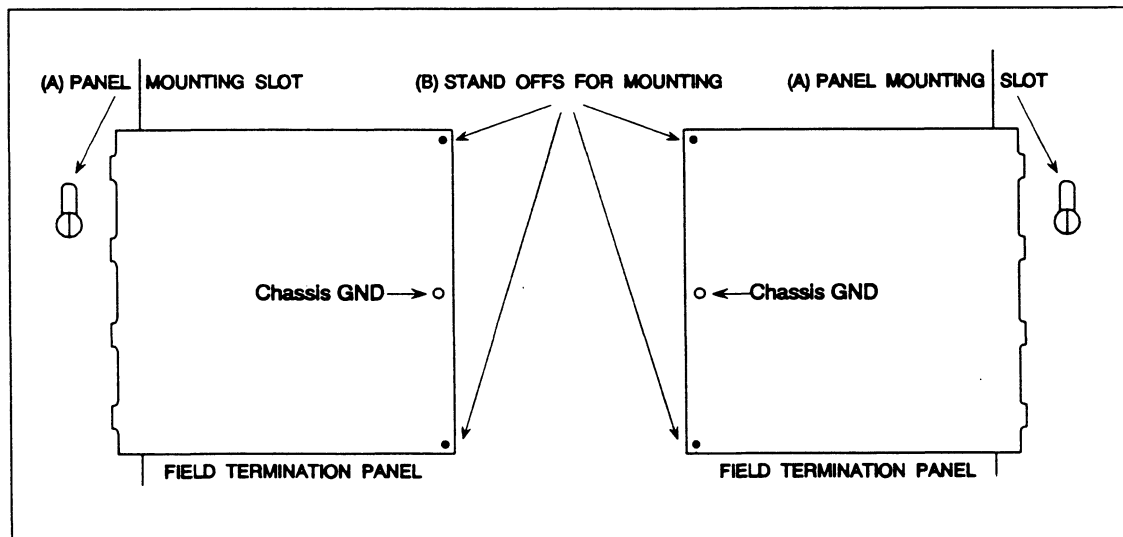

Figure 2-5. Securing the NTCF with two screws.

CABLE INSTALLATION

An NKLS01 cable connects between P1 in the T.U. and P3 on the INNIS01. An NKLS03 cable connects between P1 and the T.U. and P3 on the INLIM03. Twinax cable connects to the T.U. via terminal blocks. Coax cable connects to the T.U. via jacks. Fiber optic cable connects to T.U.'s via TX and RX optical ST connectors. See Figure 2-6 to locations.

CAUTION Exercise caution when connecting fiber optic cables. Pay strict attention to the bend radius specification pulling tensile strength during installation and normal system operation. Termination of fiber optic cable with ST type connectors must be performed by qualified personnel.

CAUTION Maintain the F.O connectors on the daughter boards and the F.O. wires covered with their plastic caps when not mated. Place the plastic caps in a safe when the F.O. connectors are mated.

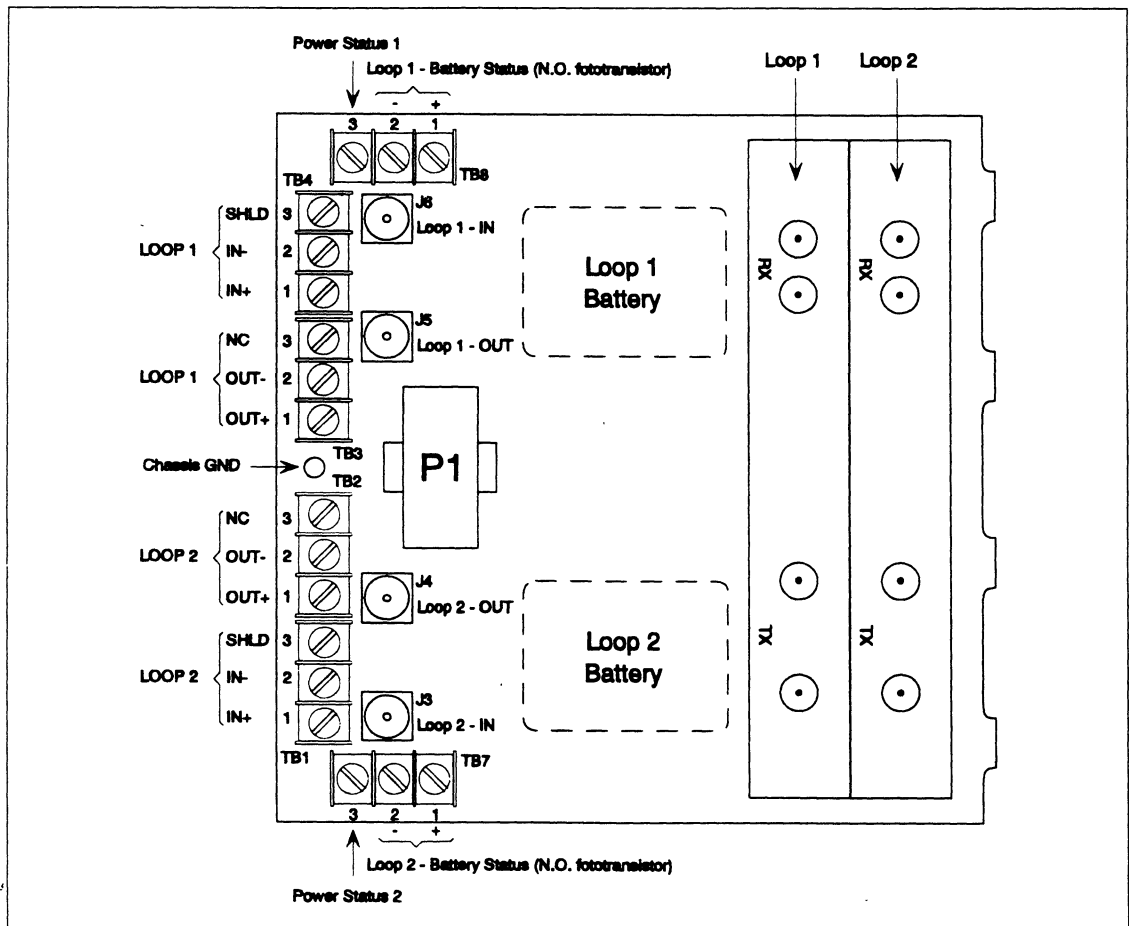

Figure 2-6. Connectors Assignment

POWER WIRING

CAUTION We strongly recommend that you turn cabinet power off before doing any termination unit wiring. Failure to do so could result in equipment damage.

Do not apply power until you verify all wire connections.

There are two terminals that provide power and ground connections. See figure 2-7. for locations. TB5 is the T.U. common and TB6 is the +34 VDC terminal.

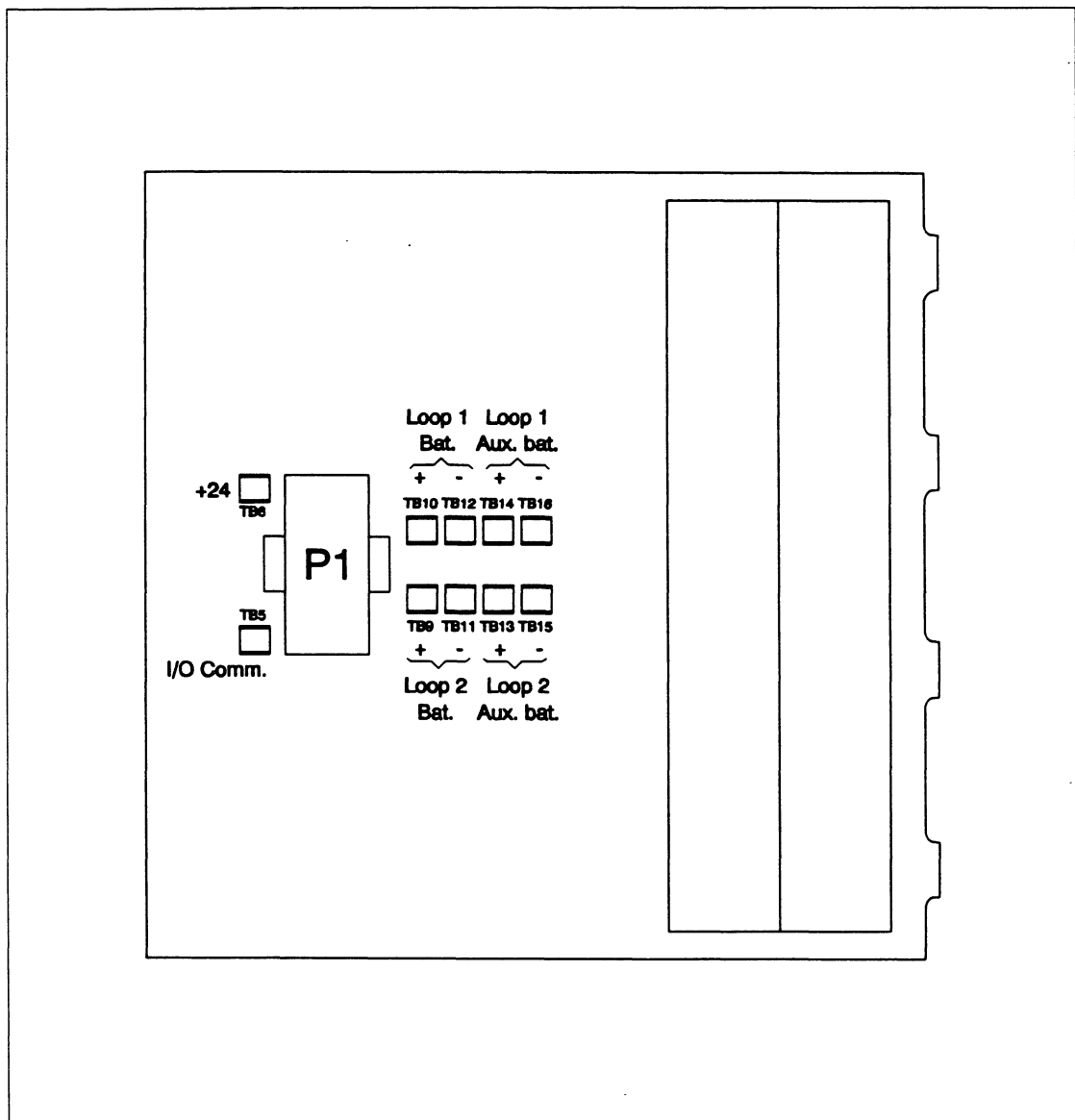

Figure 2-7. Terminals Location

BACK-UP BATTERY INSTALLATION

There are four terminals that provide power and ground Battery connections. See Figure 2-7. for locations.

1. Connect the faston "+" of the Battery 1 to the TB10 terminal of the T.U.
2. Connect the faston "-" of the Battery 1 to the TB12 terminal of the T.U.
3. Connect the faston "+" of the Battery 2 to the TB9 terminal of the T.U.
4. Connect the faston "-" of the Battery 2 to the TB11 terminal of the T.U.

WARNING

Never short circuit the terminal or wires of the back-up batteries.

WARNING

The NTCF0x are shipped with fully charged batteries. In case of long storage periods, it is recommended to verify the state of batteries before the first installation in order to be protected against power down or faults during the initial 16 h re-charge period.

Auxiliary Back-up Battery Installation

There are four terminals that provide power and ground Auxiliary Battery connections. See Figure 2-7. for locations.

1. Connect the faston "+" of the Auxiliary Battery 1 to the TB14 terminal of the T.U.
2. Connect the faston "-" of the Auxiliary Battery 1 to the TB16 terminal of the T.U.
3. Connect the faston "+" of the Auxiliary Battery 2 to the TB13 terminal of the T.U.
4. Connect the faston "-" of the Auxiliary Battery 2 to the TB15 terminal of the T.U.

SECTION 3 - MAINTENANCE

INTRODUCTION

The communication termination unit requires minimal maintenance. Doing the tasks in Table 3-1 will provide long, trouble free service. Please note that only qualified personnel should perform maintenance.

MAINTENANCE SCHEDULE

Table 3-1. is the maintenance schedule. These tasks are to be performed at the specified intervals.

Task	Interval
Clean and tighten all cable and power connections.	Every 6 months or during plant shutdown, whichever occurs first.
Use a static safe vacuum cleaner to remove dust from: Termination Units Field termination panel	

Table 3-1. Maintenance Schedule

SECTION 4 - REPAIR/REPLACEMENT PROCEDURES

INTRODUCTION

If the NTCF fails, remove and replace it with another one.

TERMINATION UNIT REPLACEMENT

CAUTION

When removing and replacing a NTCF all loop communication is lost while the termination unit is removed from the loop. For on-line replacement refer to the "On-line Replacement Procedure".

ATTENTION

Durant le démontage ou le remplacement d'une carte NTCF toute communication avec le réseau est interrompue et ce pendant tout le temps ou la carte est retirée du réseau. Pour la substitution on-line se référer à la "On-line Replacement Procedure".

If you determine that the NTCF is faulty, replace it with a new one. DO NOT try to repair the module; replacing components may affect the module performance and certification.

CAUTION

Remove modules from their assigned MMU slots before installing or removing a cable connected to that slot. Failure to do so could result in damage to the module.

ATTENTION

Retirer le module de son emplacement dans le châssis de montage des modules avant d'installer ou de retirer un câble assigné à cet emplacement. Un manquement à cette procédure pourrait endommager le module.

When replacing a termination unit, verify that:

1. All jumper settings on the replacement termination unit are the same as the failed unit.
2. The module connected to the faulty termination unit should be disconnected from its T.U. cable before that cable is disconnected from the T.U. Pull the module out of its MMU slot so that its edge connector is not in contact with the T.U. cable connected to the MMU backplane.

NOTE: Turn off power to the cabinet before removing the + 24 VDC and grounding connection to the NTCF.

Follow Steps 1 through 8 to replace the NTCF termination unit.

1. Mark the connector or terminal assignment first, then disconnect the coaxial or twinaxial or optical fiber cable from the termination unit.

INTRODUCTION

2. Disconnect the termination unit cable from the P1 socket on the termination unit.
3. Verify that the cabinet power is off, then disconnect the + 24 VDC and ground wiring from TB6 and TB5 on the termination unit.
4. Remove and save the two screws that secure that termination unit to the field termination panel, and the chassis ground screw with star washer.
5. Remove the faulty termination unit.
6. Insert the tabs of the replacement T.U. into the same slots of the termination panel standoff as shown in Figure 2-5. and slide the circuit board into position.
7. Secure the termination unit circuit board to the field termination panel with the two screws saved from Step 4. Replace the chassis ground screw and star washer.
8. Replace the + 24 VDC power wiring, reconnect the termination unit cable to P1, and reconnect the coaxial or twinaxial or fiber cables to the termination unit.
9. Insert the LIM or NIS module.

ON-LINE REPLACEMENT**WARNING**

For NTCF on-line replacement, be sure that your NTCF spare part has both batteries fully charged.

If you need to replace NTCF with the loop communication on-line, proceed as follows:

1. Pull the INNIS01/NLIM03 module out of its MMU slot so that its edge connector is not in contact with the T.U. cable connected to the MMU backplane.
2. Disconnect the loop 1 cable/optical fiber (Rx and Tx) from the faulty NTCF and connect it to the new NTCF.
After this operation be sure that the loop communication is good on both loops (by BCS or EWS consoles, the result should be: "receive errors on CHx = no").
3. Disconnect the loop 2 cable/optical fiber (Rx and Tx) from the faulty NTCF and connect it to the new NTCF. Be sure that the loop communication is good on both loops.
4. Connect the NKLS01/03 from the P1 connector on the new NTCF.
5. Disconnect the power supply from the faulty NTCF and connect it on the new NTCF (24 VDC on TB6, I/O COMM on TB5).
6. Insert the INNIS01/NLIM03 module in the MMU.
7. Reset the module INNPM01/NBIM02.

ON-LINE REPLACEMENT

SECTION 5 - SUPPORT SERVICES

INTRODUCTION

Elsag Bailey is ready to help in the use and repair of its products. Contact your nearest sales office to make requests for sales, applications, installation, repair, overhaul and maintenance contract services.

TECHNICAL DOCUMENTATION

You can obtain additional copies of this manual from the nearest Elsag Bailey sales office at a reasonable charge.

For prompt, personal attention to your instrumentation and control needs or a full listing of
Bailey representatives in principal cities around the world, contact the Bailey location nearest you.

Australia

Bailey Australia Pty. Limited
26 Auburn Road
Regents Park, New South Wales 2143
Telephone: 61-2-645-3322
Telefax: 61-2-645-2212

Brazil

Bailey do Brasil
Alameda Campinas 463,
conj. 5A and 5B
01404-902 Sao Paulo SP
Telephone: 55-11-288-4000
Telefax: 55-11-289-0057

Canada

Bailey Canada
860 Harrington Court
Burlington, Ontario L7N 3N4
Telephone: 1-905-639-8840
Telefax: 1-905-639-8639

China, People's Republic of

Bailey Beijing Controls Co., Ltd.
41 Gulou West Street
Beijing
Telephone: 86-1-401-0651
Telefax: 86-1-401-1643

France

Elsag Bailey SA
100, rue de Paris
Massy Cedex 91342
Telephone: 33-1-64-47-2000
Telefax: 33-1-64-47-2016

Germany

Bailey MD Automation GmbH
Zum Alten Wasserwerk 9
5063 Overath 6, Cologne
Telephone: 49-220-4-739-0
Telefax: 49-220-4-739-79

Italy

Elsag Bailey
Via Puccini 2
16154 Genova
Telephone: 39-10-658-2-944
Telefax: 39-10-658-2-941

Japan

Bailey Japan Company, Ltd.
511 Baraki, Nirayama-Cho
Tagata-Gun, Shizuoka-Ken, 410-21
Telephone: 81-559-49-3311
Telefax: 81-559-49-1114

Jordan

Bailey Controls Jordan
P.O. Box 2310
Amman
Telephone: 962-6-756-908
Telefax: 962-6-756-908

Mexico

Bailey Mexico, SA de CV
Felix Guzman No. 15
Col. El Parque
Naucalpan, Edo de Mexico 55390
Telephone: 52-5-557-6100
Telefax: 52-5-395-3984

Netherlands

Bailey Nederland BV
P.O. Box 572, 3190 AM Botlek Rt.
Welplaathoek 20
3197 KP Botlek/Rotterdam
Telephone: 31-10-416-9696
Telefax: 31-10-416-9423

Norway

Bailey Petrovest AS
Box 93, Kokstaddalen 4
N-5061 Kokstad, Bergen
Telephone: 47-55-229-601
Telefax: 47-55-229-610

Singapore

Elsag Bailey Pte. Ltd.
750 E. Chai Chee Road, 05-03
Singapore, 1646
Telephone: 65-442-3200
Telefax: 65-442-2700

United Kingdom

Bailey ICS plc
Hortonwood 37
Telford, Shropshire TF1 4GT
Telephone: 44-952-670-477
Telefax: 44-952-670-455

United States

Bailey Controls Company
29801 Euclid Avenue
Wickliffe, Ohio 44092
Telephone: 1-216-585-8500
Telefax: 1-216-585-8756

Electronic Technology Systems, Inc.
P.O. Box 366
New Kensington, Pennsylvania 15068
Telephone: 1-412-335-1300
Telefax: 1-412-335-2450

Network Management Technology, Inc.
P.O. Box 5031
Sugar Land, Texas 77487
Telephone: 1-713-274-5000
Telefax: 1-713-240-6986

Venezuela

Bailey de Venezuela S.A.
Este Oeste No. 6, Parcela 216, 218
Galpon No. 4
Valencia
Telephone: 58-41-405-138
Telefax: 58-41-322-994